

THE INFORMATION CONTAINED IN THIS DRAWING IS THE SOLE PROPERTY OF SPEC INC. ANY REPRODUCTION IN PART OR WHOLE WITHOUT THE WRITTEN PERMISSION OF SPEC INC. IS PROHIBITED.

REVISIONS			
REV.	DESCRIPTION	DATE	APPROVED

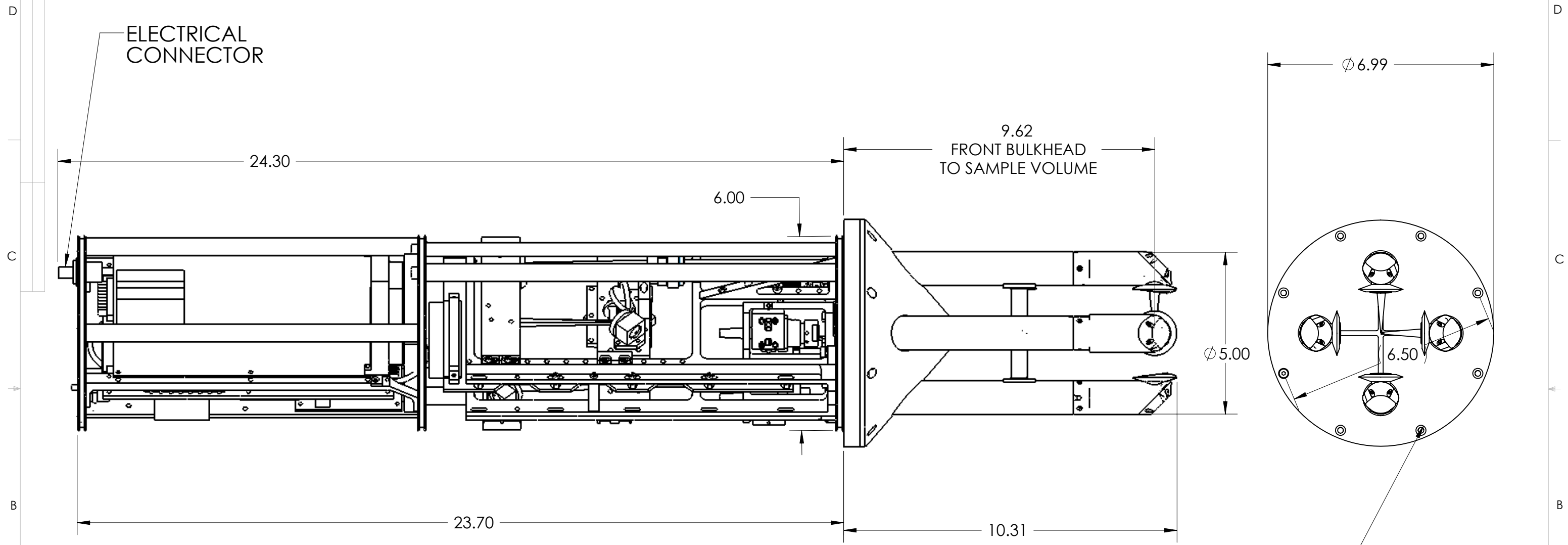

USE 8X #8-32 SHCS ON
 ϕ 6.50 BOLT CIRCLE
 STANDARD PMS CAN
 MOUNTING PATTERN

INSTRUMENT MOUNTS IN A STANDARD SIZE PMS CAN
 * HERMETICALLY SEALED CAN RECOMMENDED - CONTACT
 SPEC FOR DETAILS

SENSOR WEIGHT: 19 LBS

ITEM NO.	PART OR IDENTIFYING NO.	NOMENCLATURE OR DESCRIPTION	MATERIAL SPECIFICATION	QTY REQD
PARTS LIST				
UNLESS OTHERWISE SPECIFIED DIMENSIONS ARE IN INCHES TOLERANCES ARE:		CAD GENERATED DRAWING, DO NOT MANUALLY UPDATE		
FRACTIONS DECIMALS ANGLES		APPROVALS DATE		
+ .XX+ .XX + 1 .XXX+.XXX		DRAWN P. ZMARZLY 01/10/07		
MATERIAL -		CHECKED		
FINISH -		RESP ENG		
NEXT ASSY USED ON		MFG ENG		
APPLICATION		QUAL ENG		
DO NOT SCALE DRAWING		SCALE CAD FILE:		

SPEC INC.

3022 STERLING CIRCLE
 SUITE 200
 BOULDER, CO 80301
 303-449-1105

**2D-S INSTRUMENT
 OVERALL DIMENSIONS**

REV. 1

SHEET 1 OF 1